

ABS submersible drainage pump XJ 50

GB 50

Specification

Electric submersible pump.
 Maximum submergence: 20 m. • Protection class IP 68.
 Max temperature of pumped medium at max power input and continuous duty 40 °C.
 Max medium density 1100 kg/m³. • pH of the pumped medium 5-8.
 Strainer hole: 7.5 x 22 mm.
 Max number of starts 30/hour.

- XJ 50 ND, Medium head, 3-phase**
- XJ 50 ND AT*, Medium head, 3-phase**
- XJ 50 LD, High flow, 3-phase**
- XJ 50 LD AT*, High flow, 3-phase**
- XJ 50 HD, High head, 3-phase**
- XJ 50 HD AT*, High head, 3-phase**

*AquaTronic: Built in electronic pump control as option.

Electric Motor

3-phase squirrel-cage induction motor, 50 Hz
 Service factor 1.1. Class F insulation.
 Motor rating P₂: 5.6 kW. 2 pol. Speed: 2930 rpm
 η: 86.7 (50 %), 90.8 (75 %), 89.6 (100 % load)

Voltage, V	230	400	500	1000
Nominal current, A	19.7	11.3	9.0	4.5

Starting Method and Motor Protection

XJ 50 AT: Direct on line start (DOL 230-500 V) with built in AquaTronic unit, which automatically adjusts phase order by dual contactors, ensuring correct motor rotation.
 Soft start (230-500 V) is available as a built in option with the AquaTronic unit, where three thyristors reduces start current to three times the nominal current. Here two relays ensures correct motor rotation
 The AquaTronic unit monitors motor temperature, by use of NTC thermistors built into stator windings, and stops the motor at high temperature. It will also stop the motor at high amperage or if a phase is missing.

XJ 50: Direct on line start with built in contactor. Pumps to be used with VFD or 1000 V must have terminal block instead of contactor. Thermal switches (140 °C, ±5) built into the stator windings are connected to the contactor and stops the pump at high temperature.

Power Cable

20 m type S1BN8-F (standard cable):
 4 x 2.5 sq.mm. (230 V)
 4 x 1.5 sq.mm. (400-500 V)

20 m type NSSHÖU.../3E (heavy duty cable):
 3x2.5+3x2.5/3E+3x1.5 (3 control cables included) (1000 V or terminal block)
 3x2.5+3x2.5/3E (230 V)
 3x1.5+3x1.5/3E (400-500 V)

Shaft Seal

Double mechanical seal in oil bath.
 Primary seal: Silicon carbide on silicon carbide
 Secondary seal: Silicon carbide on silicon carbide

Bearings

Upper bearing: Single-row deep groove ball bearing.
 Lower bearing: Double angular contact ball bearing.

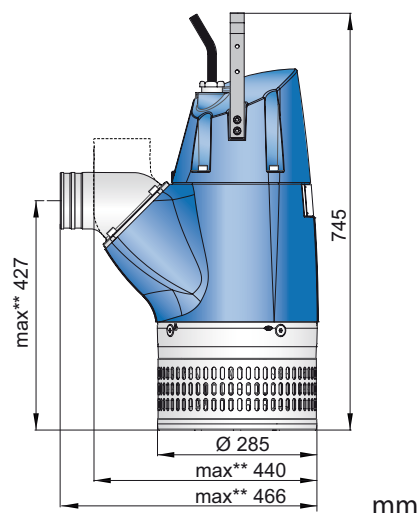
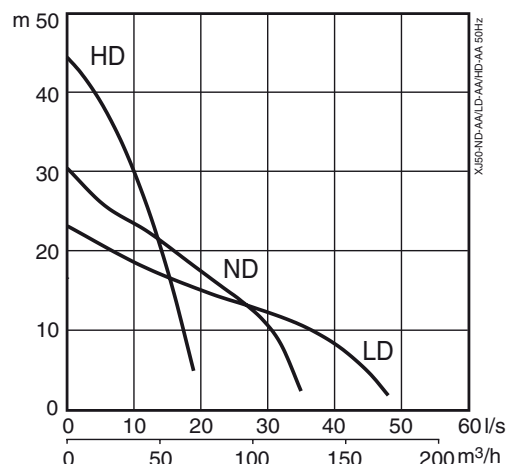

** Max measurement based on largest discharge size.

Discharge Connections

3" (standard HD), 4" (standard ND), 6" (standard LD) hose connections.
 3", 4", 6" G/B.S.P. threaded connections.

Weight (without cable)

59 kg

Options and Accessories

AquaPlug • Level sensor • Service data kit
 Zinc anodes • Surface protection coating
 Series connection • Floatation ring
 Discharge connection accessories and hose

Pump control	XJ 50	XJ 50 AT				
Features		AT	AT + Level Sensor	AT + AquaPlug	AT + AquaPlug + Level Sensor	Service Data Kit Read out
Run mode	•	•	•	•	•	
Integrated start equipment	•	•	•	•	•	
Automatic direction of rotation		•	•	•	•	
Motor protection high temp	•	•	•	•	•	•
Motor protection high amp		•	•	•	•	•
Protection against missing phase		•	•	•	•	•
Level control			•		•	
Dry run protection			•	•	•	
Automatic restarting			•	•	•	
Stop mode				•	•	
E-mode (Automatic stop/run)				•	•	
Indication of water in oil				•	•	•
Indication of low motor insulation				•	•	•
Indication of high or low voltage				••	••	•
Indication of high temperature				••	••	•
Indication of high amp				••	••	•
Indication of phase unbalance				••	••	•
USB cable connection		•	•	•	•	•
Crash logg (10 latest)						•
Documentation (spare part list, workshop manual)						•

- Fault indication when pump is automatically stopped to protect the motor.

Materials

Description	Material	EN	ASTM
Castings	Aluminium	EN 1706:AC-43100	ASTM A1Si10mg
Strainer/Handle	Stainless steel	10088:X5CrNi18-10 (1.4301)	AISI 304
Rotor shaft	Stainless steel	10088:X20Cr13 (1.4021)	AISI 420
Impeller	White cast iron	EN-GJN-HV600(XCr23)	ASTM A 532: Alloy III A
Fasteners	Stainless steel	10088:X5CrNiMo 17122 (1.4401)	AISI 316
Wear parts / O-rings	Nitrile rubber		
Coating	2 component epoxy paint 80 µm		

SULZER

abs