

Customer	Project	Page	1 / 1
Customer no.	Project no.	Date	25/04/2013
Contact	Position	SERIES A, AX	
Care of	Location		

A 401 11 5745.0150
 Variable speed Mini Energy Pump

Requested data

Flow	0 m³/h
Head	0 m
Fluid	Water, pure
Temperature	20 °C
Working pressure	10 bar

Operating data

Flow	0 m³/h
Head	0 m
Speed stages	
Power input P1	0.00 kW
Permitted working pressure	16 bar
Min. fluid temperature	15 °C
Max. fluid temperature	95 °C

Required working pressure

Values are valid for hot water,
 Altitude 500m above sea level.

Changing of required working pressure at +/- 0.01bar
 per +/- 100m altitude above sea level.

75 °C	95 °C
0.1 bar	0.55 bar

Pump data

Installation dimension	DN 40 x 220
Rated voltage	1~230 V 50
Rated current	1.25 A
Rated power P2	0.174 kW
Insulation class	F
Degree of protection	IP 44

**Short-circuit-proof motor doesn't
 required overload protection.**

Materials

Pump casing	Cast iron
Impeller	Plastic
Can	Chrome-Nickel Steel
O- Ringe	EPDM 75
slide bearing	Ceramic
Shaft	Ceramic

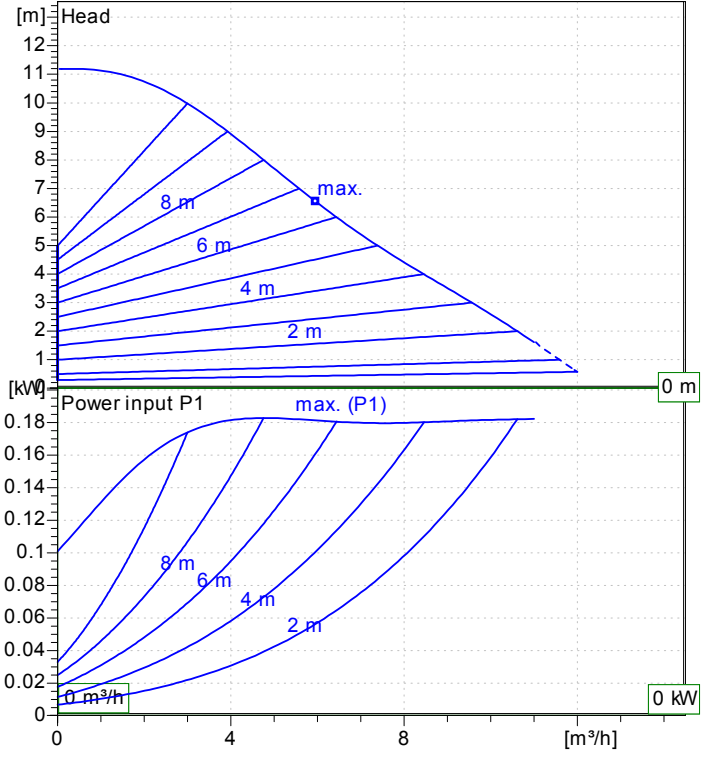
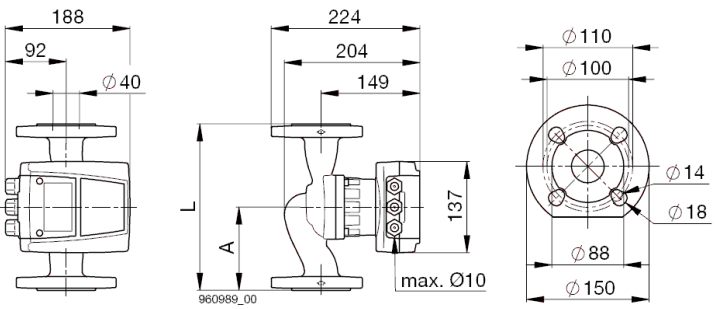

Weight 9 kg

51-54: Error message
 (potential-free closing
 contact closed if there
 is a malfunction)
 contact load max.250V~,1A

51-52:
 (Zero potential normally - closed contact,
 open with fault)
 Contact load max.250V~,1A

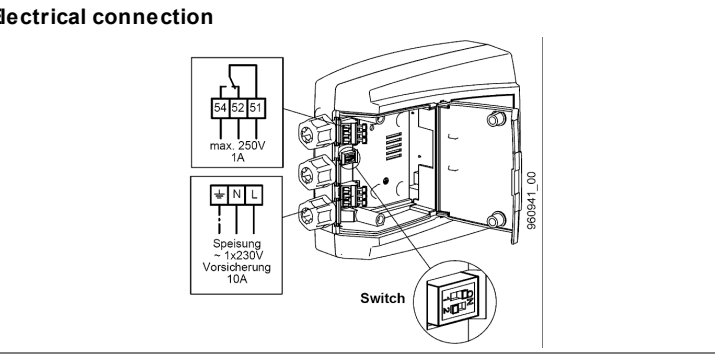

Remarks: