

# 570Z Series Sprinklers

## S P R I N K L E R S

Featuring a low-pressure seal that flushes only upon retraction, 570Z models are ideal for small garden and turf areas. Seven distinct pop-up sprinkler bodies and a host of interchangeable nozzles provide unlimited design flexibility.

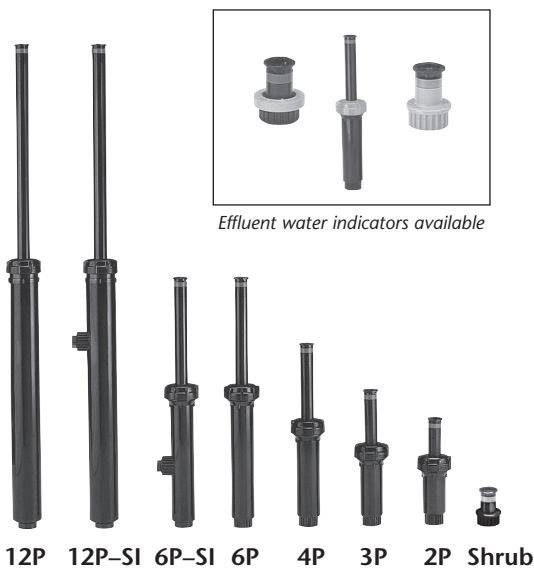

MPR Plus nozzle with standard PCD's

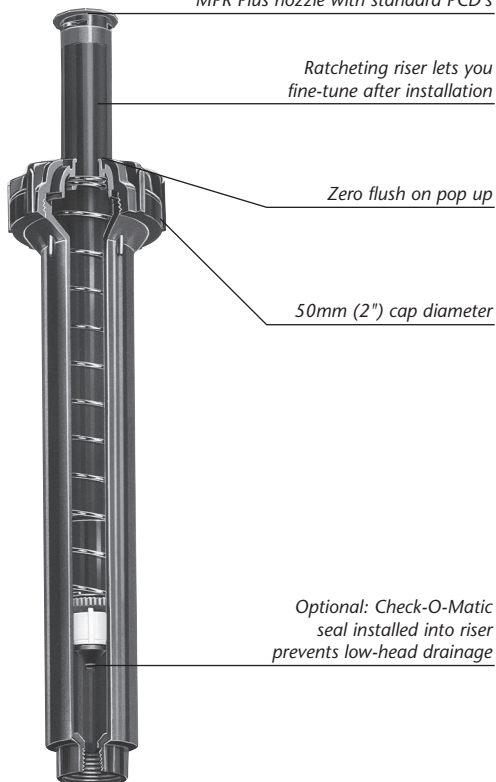

Optional: Check-O-Matic seal installed into riser prevents low-head drainage

570Z-6P-COM

### 0-5,2m (0'-17') Radius

#### Features

- Zero flush seal prevents flushing on pop-up, enabling more heads to be placed on same zone
- Low-pressure sealing at 1 Bar (15 PSI)
- Retraction flushing clears debris for reliable pop-down
- Small, 50mm (2") diameter black cap is less visible, reducing damage from exposure or vandals
- Accepts all Toro spray nozzles – including 570 MPR Plus fixed, Toro Variable Arc, bubbler and low angle nozzles
- Accepts Maxijet® nozzles for low-application-rate irrigation
- All bodies shipped with a flush plug in place for ease of flushing and riser pull up
- Ratcheting riser feature for easy and reliable arc adjustment
- Side-inlet models available on both 150mm (6") and 300mm (12") non-COM sprinkler bodies for sandy soils or applications prone to high pressure surges and spikes
- Check valve models with heavy-duty retraction spring prevent low-head drainage and keep laterals charged with water (optional)
- Durable engineering plastic construction
- Stainless-steel retraction spring

#### Specifications

- Spacing: 0.6-5.2m (2'-17')
- Flow rate: 0.2-17 LPM (0.05-4.58 GPM)
- Recommended operating pressure: 1.4-3.5 Bar (20-50 PSI)
- Minimum operating pressure for COM models: 1.7 Bar (25 PSI)
- Maximum operating pressure: 5.2 Bar (75 PSI)
- 13mm (1/2") female-threaded inlet
- Check valve maintains up to 3m (10') in elevation change (Check-O-Matic feature requires use of the bottom inlet.)
- Dimensions:
  - Body diameter:
    - 35mm on 50, 75, 100 and 150mm
    - (1<sup>3</sup>/<sub>8</sub>" on 2P, 3P, 4P, 6P and 6P-SI) bodies
    - 41mm on 300mm (1<sup>5</sup>/<sub>8</sub>" on 12P) bodies
    - 44mm on 300mm (1<sup>3</sup>/<sub>4</sub>" on 12P-SI) bodies
  - Cap diameter: 50mm (2")
  - Side inlet: 120mm (4<sup>3</sup>/<sub>4</sub>") from top of sprinkler to center of side inlet

## Specifying Information

Specifying Information				
570Z XXP SI COM E				
Pop-Up Height		Optional	Optional	Optional
S – Shrub 2 – 50mm (2") 3 – 75mm (3")	4 – 100mm (4") 6 – 150mm (6") 12 – 300mm (12")	SI – Side Inlet optional for 150 and 300mm (6" and 12")	COM – Check-O-Matic*	E – Effluent
For Example: When specifying a 570Z Series Sprinkler with a pop-up height of 150mm (6") and a check valve, you would specify: <b>570Z-6P-COM</b>				

\*Not available on side inlet models.

### Toro 570 Shrub Adapters

For use with any 570 MPR Plus spray, stream bubbler or Maxijet® nozzle to effectively irrigate small shrubs and planters in non-traffic areas. Accepts all Toro nozzles and filter screens, and installs onto a 13mm (1/2") NPT riser.



### Toro Risers and Extenders

Modify existing systems to irrigate small shrubs and planters in non-traffic areas. For use with any 570 MPR Plus spray, stream bubbler or Maxijet® nozzle.

#### Features

- Male-inlet threads install onto any 570Z pop-up spray sprinkler or 570 shrub adapter to provide a 150mm (6") extension (570-6X)
- Accepts all Toro nozzles and filter screens
- Durable engineering plastic construction
- Stabilizer available for 2P, 3P, 4P, and 6P models
- 570 female-outlet threads accept all Toro nozzles
- Maximum pressure: 5,2 Bar (75 PSI)
- Height:

150mm (6") for 570SR-6,  
460mm (18") for 570SR-18

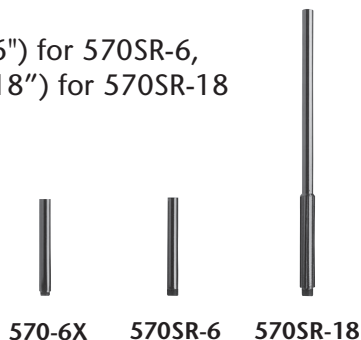

### 850-67 Stabilizer

- Fits all 570Z 2P, 3P, 4P and 6P bodies

### Effluent Water Indicators

Use with any 570Z Series sprinkler or 570 shrub adapter to identify the effluent water system.

#### 89-5818

- Lavender snap-on cover for use on 570S Series shrub adapters



89-5818

#### 102-0563

- Lavender molded cover for use on 570Z Series pop-up models



102-0563

#### 570S-E

- Lavender molded 570Z Series shrub adapter for effluent applications
- Installs onto a 13mm (1/2") NPT riser



570S-E

### Installation/Adjustment Tools

#### 89-6395

- Riser pull-up tool for 570Z Series models



89-6395

#### 102-1777

- X-tool for 570Z XF and PRX Series models (redirects spray of water until X-Flow® device is activated.)



102-1777

#### 89-7350

- Adjustment tool for 570Z Series models



89-7350



Toro Irrigation Products distributed by:

Lely (UK) Ltd  
1, Station Road  
St. Neots  
Cambridgeshire  
PE19 1QH

Tel: (01480) 226800

Fax: (01480) 226881

GB Form Number: LUK200-2754

©2005 The Toro Company – All Rights Reserved